

STRAIGHT MALE RECEPTACLE FOR PCB

R222.508.000

SMT TYPE - FULL DETENT - REEL 500

Series : SMP

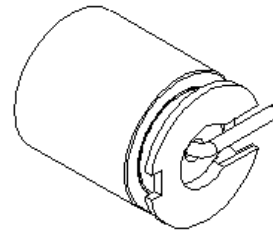
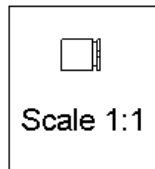
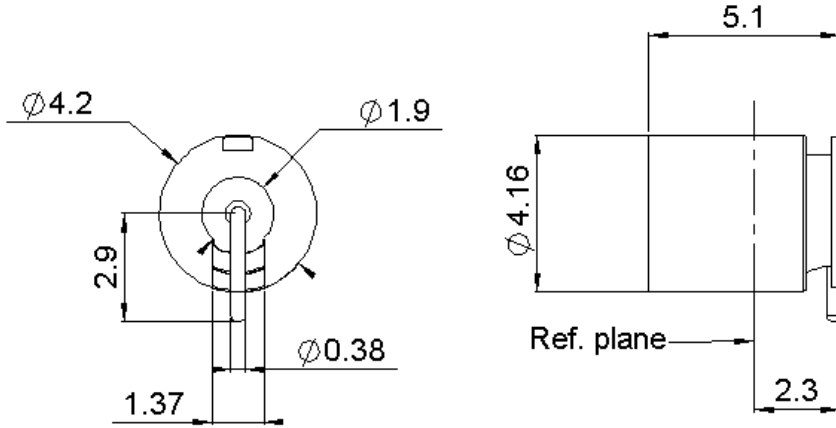

All dimensions are in mm.



COMPONENTS	MATERIALS	PLATINGS (µm)
BODY	STAINLESS STEEL + BRASS	PASSIVATED + GOLD 0.5 OVER NICKEL2
CENTER CONTACT	BERYLLIUM COPPER	GOLD 1.27 OVER NICKEL 1.27
OUTER CONTACT		
INSULATOR	PTFE	
GASKET		
OTHERS PARTS	-	-
-	-	-
-	-	-

Issue : 0529 B

In the effort to improve our products, we reserve the right to make changes judged to be necessary.



STRAIGHT MALE RECEPTACLE FOR PCB

R222.508.000

SMT TYPE - FULL DETENT - REEL 500

Series : SMP

PACKAGING

SPECIFICATION

Standard	Unit	Other
500	'W' option	Contact us

ELECTRICAL CHARACTERISTICS

ENVIRONMENTAL

Impedance		50 Ω
Frequency		0-12 GHz
VSWR	1.15 +	0.000 x F(GHz) Maxi
Insertion loss		0.12 √F(GHz) dB Maxi
RF leakage	- (NA - F(GHz)) dB Maxi
Voltage rating		335 Veff Maxi
Dielectric withstanding voltage		500 Veff mini
Insulation resistance		5000 MΩ mini

Operating temperature	-65/+165 ° C
Hermetic seal	NA Atm.cm3/s
Panel leakage	NA

OTHERS CHARACTERISTICS

Assembly instruction

Others :
Compliant with MIL-STD-348

MECHANICAL CHARACTERISTICS

Center contact retention		
Axial force – Mating end	6.8	N mini
Axial force – Opposite end	6.8	N mini
Torque	NA	N.cm mini
Recommended torque		
Mating	NA	N.cm
Panel nut	NA	N.cm
Mating life	100	Cycles mini
Weight	0.320	g

Issue : 0529 B

In the effort to improve our products, we reserve the right to make changes judged to be necessary.



STRAIGHT MALE RECEPTACLE FOR PCB**R222.508.000****SMT TYPE - FULL DETENT - REEL 500**

Series : SMP

SOLDER PROCEDURE

1. Deposition of solder paste 'Sn Ag4 Cu0.5' on mounting zone by screen printing application. We recommend a low residue flux.
We advise a thickness of 150 microns (5.85 microinch). Verify that the edges of the zone are clean.
2. Placement of the receptacle on the mounting zone with an automatic machine of 'pick and place' type.
Video camera is recommended for the positioning of the component. Adhesive agents must not be used on the receptacle.
3. Soldering by infra-red reflow.
Below, please find the typical profile to use.
4. Cleaning of printed circuit boards.
5. Checking of solder joints and position of the component by visual inspection.

TEMPERATURE PROFILE

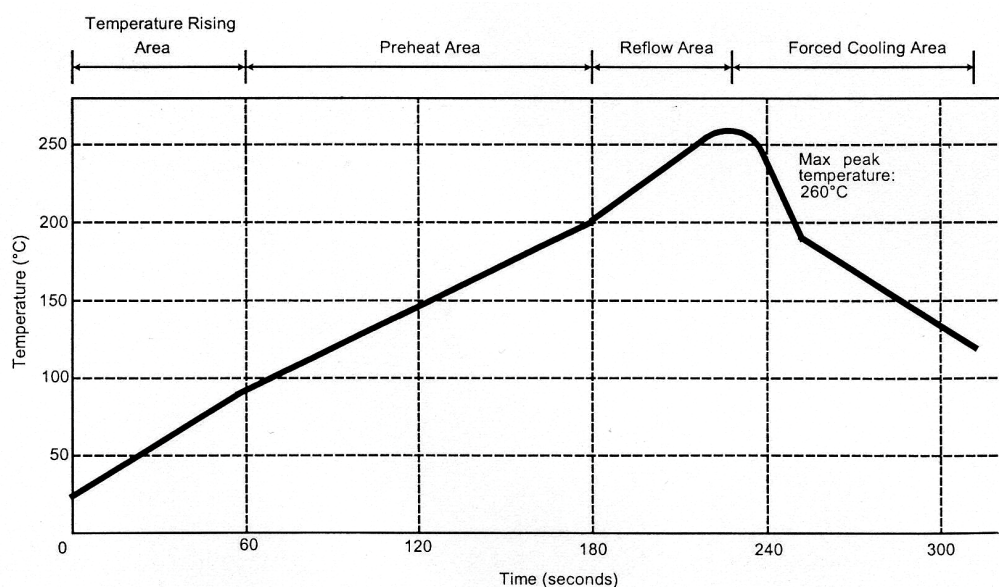

Parameter	Value	Unit
Temperature rising Area	1 - 4	°C/sec
Max Peak Temperature	260	°C
Max dwell time @260°C	10	sec
Min dwell time @235°C	20	sec
Max dwell time @235°C	60	sec
Temperature drop in cooling Area	-1 to - 4	°C/sec
Max dwell time above 100°C	420	sec

Issue : 0529 B

In the effort to improve our products, we reserve the right to make changes judged to be necessary.



STRAIGHT MALE RECEPTACLE FOR PCB

SMT TYPE - FULL DETENT - REEL 500

R222.508.000

Series : SMP

SHADOW OF
THE RECEPTACLE

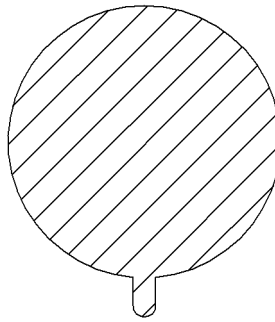

FOR VIDEO CAMERA

PCB mounting pattern

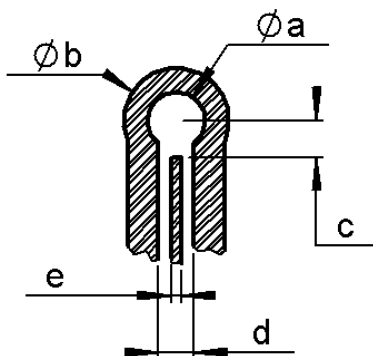

a	1,91
b	4,45 min.
c	2,29 min.
d	1,52
e	0,38 max.

Issue : 0529 B

In the effort to improve our products, we reserve the right to make changes judged to be necessary.



STRAIGHT MALE RECEPTACLE FOR PCB

SMT TYPE - FULL DETENT - REEL 500

R222.508.000

Series : SMP

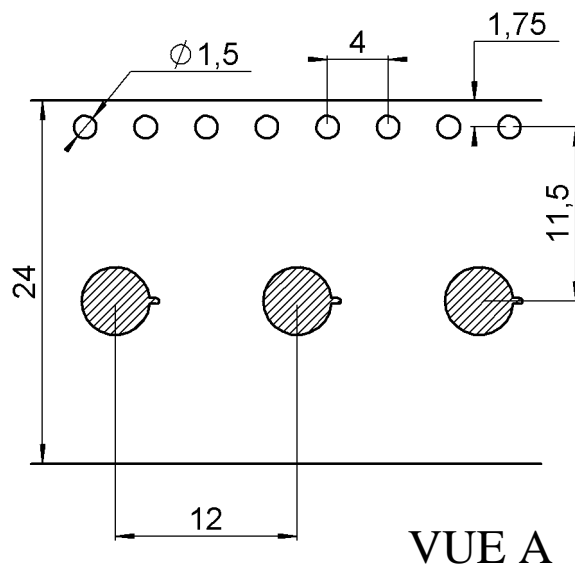
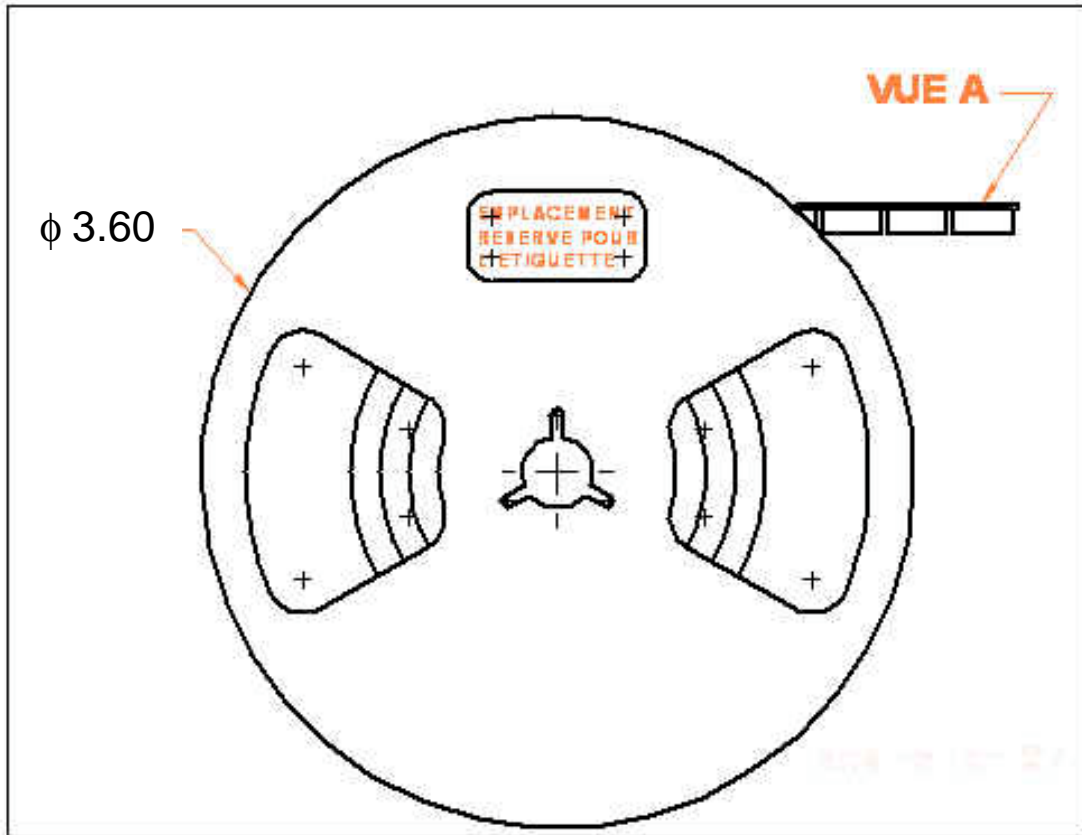

Issue : 0529 B

In the effort to improve our products, we reserve the right to make changes judged to be necessary.

